

DIGIPLAN[®] *presents...*

Portable Folding Chair



Unfolded View



Folded Side View

We are offering these plans for no charge as an example of what you can expect when you purchase other plans offered on this site.

This is an easy little starter project that should only take a few hours. When finished you should have a very strong, practical hunting, fishing etc, chair that folds up for easy transport.

If you have questions or concerns when building this chair, please send us a note at prod.support@digiplan.ca and expect a reply within 24 hours.

Good luck and please visit us again at www.treestandplans.ca or www.digiplan.ca for other products we offer.

Sincerely

A handwritten signature in black ink, appearing to read 'QZ', written in a cursive style.

*Quinn Zander
Design Manager*

Step 1 – Required Tools

Time and effort spent building this stand will depend greatly on the tools available to you. At a minimum, you will need the following:

- Hacksaw
- 3/8" drill and bits
- Soapstone
- Tape Measure
- Welder (gloves, helmet, safety glasses)
- Center punch
- Hammer
- Bench vice
- C clamps or vice grip clamps
- Square

Step 2 – Raw Materials

You will need the following materials to build this chair:

- 1" X 1" X .100 Square Tubing (8 ft)
- ¼" Schedule 40 Pipe (2 ft)
- 3/16" X 1" Flat Bar (4 ft)
- 5/16" NC All Thread Rod (2 ft -usually comes in 3ft lengths)
- 5/16" NC Nylock Nuts (4pcs)
- 5/16" NC Regular Hex Nuts (2pcs)
- 5/16" X 2 ½" Hex Bolts (2pcs)
- 1/8" X 2" Nylon Webbing (7 ft)
- Paint

Step 3 - Prepare Steel

Please note this pdf document contains "hot links". Use your mouse to click on the underlined words in this document to automatically be taken to the appropriate drawing(s).

1. Out of the 1" tubing mark the miters (angled edges) and cut the leg tubes. Each set (long and short) of tubes are mirror images so ensure that the angles are correct by referring to the drawings.
2. Mark and drill the holes in the leg tubes.
3. With the 1" flat bar, cut 2 pieces 13" and 2 pieces 10" in length for the long and short spread bars
4. With the ¼ pipe, cut 1 piece 12" and 1 piece 10" for the long and short wrap bars
5. With the 5/16" all thread rod, cut 1 piece 13" and 1 piece 11" for the long and short threaded rods
6. Out of the Nylon web, cut 4 pieces 21"

Step 4 – Assembly

Please read through the instructions to ensure you have a mental picture of how this chair is constructed. Remember you may click on underlined words to go directly to the associated picture.

Long Leg Assembly:

Thread a 5/16" hex nut onto one end of the long thread rod and allow approx. 1/8" of thread to stick out past the nut. Weld this nut to the threaded rod to effectively make a long bolt.

Assemble the 2 long leg tubes, long wrap bar, and long thread rod. With another 5/16" nut, snug the assembly together just tight enough to still allow some movement.

Clamp the assembly down to ensuring proper orientation to fit the lower long spread bar. Square the assembly, locate the lower long spread bar and tack it in place.

Flip the assembly over and locate and tack the upper long spread bar. Weld the long spread bars to the leg tubes. **Do not weld the inner joint**, as the short leg assembly must fold tight to the inner edge.

Short Leg Assembly:

Weld a 5/16" hex nut to the short thread rod in the same manner as was used for the long thread rod. Bolt up the assembly and orient it to ensure that the lower short spread bar will lay flush to the table.

Clamp and square the assembly. Keep in mind that this assembly must fit inside the long leg assembly. Ensure that there is a minimum of 1/32" clearance between the 2 assemblies. You may need to grind down the short wrap bar and/or the short spread bars.

Once the clearance has been checked, locate the lower short spread bar and tack it in place. Flip the assembly over, locate and tack the upper short spread bar, then weld them to the leg tubes.

Finishing Up:

Before painting, it is wise to dry fit the chair to ensure fit-up.

Place the short leg assembly into the long leg assembly and bolt them together with the 2 1/2" bolts and lock nuts.

Unbolt the threaded rods and remove the wrap bars. If you had the nylon web straps pre-sewn at an upholstery shop, slip the straps over the wrap bars, and re-fit them into the leg assemblies.

If you choose to sew the straps yourself, lap the ends back to the 4 3/4" mark and sew as shown. It is wise to melt the cut ends of the straps with a lighter to prevent them from fraying (before you sew them).

Important – Please Read

We cannot be responsible for incorrect construction of this product. Please make sure all welds are strong before using this folding chair. Also note these plans are protected under copyright law, unauthorized reproduction or distribution of these plans is prohibited without written consent from Digiplan.

2

1

Folding Chair Parts List				
ITEM	QTY	PART NAME	DESCRIPTION	AMOUNT
1	4	Chair Web	1/8 X 2 Nylon Web	21 in
2	2	Nylock Nut	5/16 Std NC Nylock Nut	1
3	2	5-16 x 2 1-2 NC Gr5 Hex Bolt	5/16 x 2 1/2 NC Hex Bolt	1
4	1	Long Leg Assembly	Weldment	1
5	1	Short Leg Assembly	Weldment	1

B

B



ERECTED POSITION

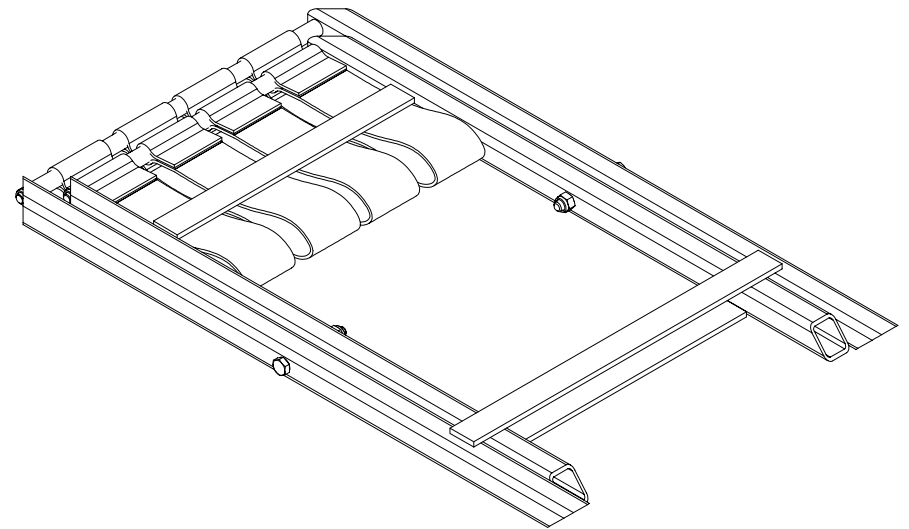

FOLDED POSITION

A

A

2

1

SHT 1

MATERIAL		DigiPlan		
Weldment				
UPPER LEVEL ASSEMBLY		DRAWN	QBZ	TITLE
Folding Chair		REV	B	Folding Chair Assembly
WEB ADDRESS		CONTACT INFO		DWG NAME
www.digiplan.ca		prod.support@digiplan.ca		Folding Chair

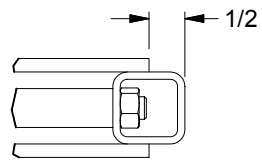

DETAIL A

NO WELD ZONE

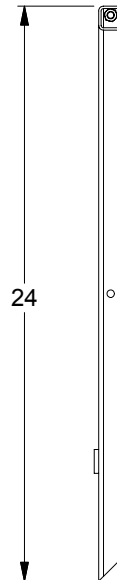
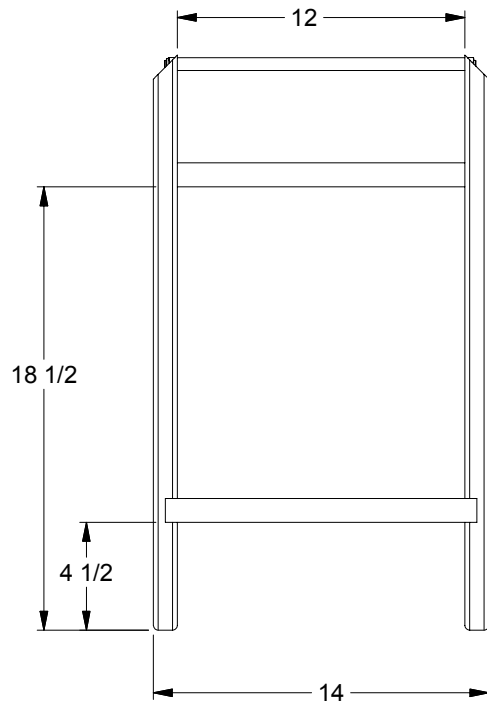
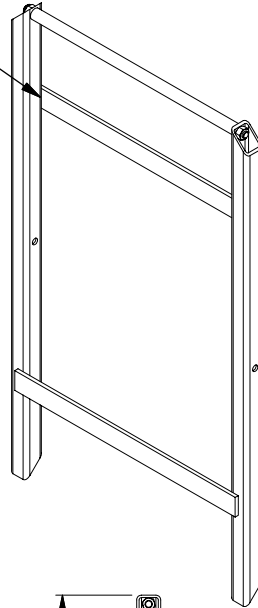

Long Leg Parts List				
ITEM	QTY	PART NAME	DESCRIPTION	AMOUNT
1	1	Long Leg	1 X 1 X .100 Sq Tube	24 in
2	1	Long Leg LH	1 X 1 X .100 Sq Tube	24 in
3	1	Long Wrap Bar	1/4 Sched 40 Pipe	12 in
4	2	Long Spread Bar	3/16 X 1 Flat Bar	13 in
5	1	Long Thread Rod	5/16 All Thead	13 in
6	1	5_16-18 NC Hex Nut	5/16 NC Hex Nut	1
7	1	Nylock Nut	5/16 Std NC Nylock Nut	1

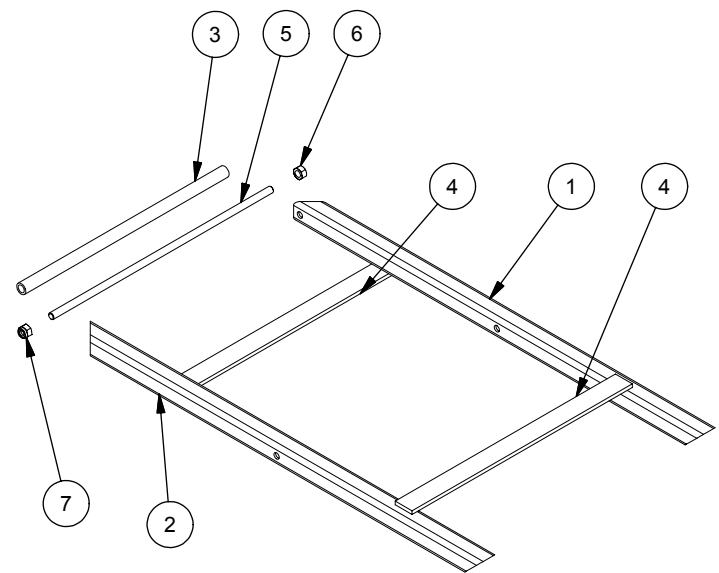

SHT 2

MATERIAL		DigiPlan		
Weldment				
UPPER LEVEL ASSEMBLY		DRAWN	QBZ	TITLE
Folding Chair		REV	B	Long Leg Assembly
WEB ADDRESS	CONTACT INFO	DWG NAME		
www.digiplan.ca	prod.support@digiplan.ca	Folding Chair		

2

1

B

B

A

A

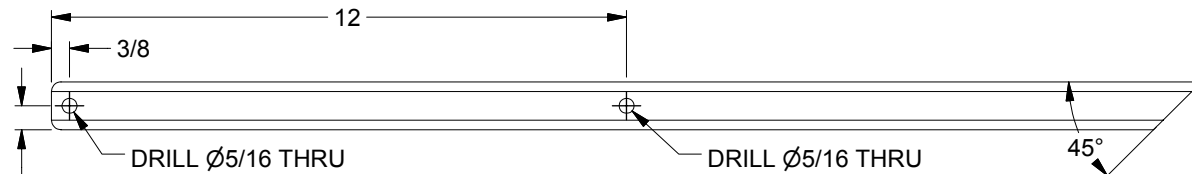
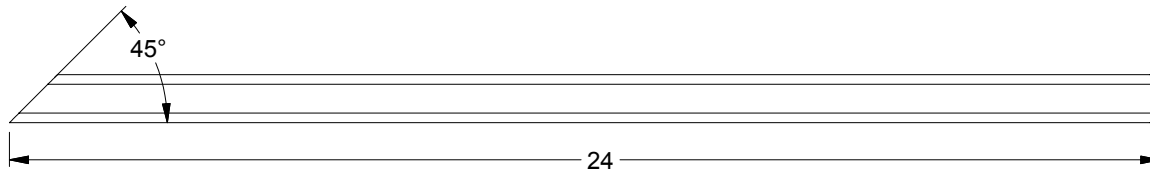

ITEM: 1 PART NAME: LONG LEG QTY: 1
 DESCRIPTION: 1 X 1 X .100 SQ TUBE

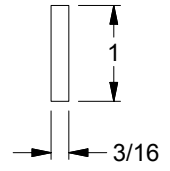
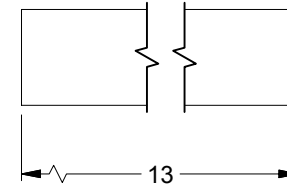

ITEM: 4 PART NAME: LONG SPREAD BAR QTY: 2
 DESCRIPTION: 3/16 X 1 FLAT BAR

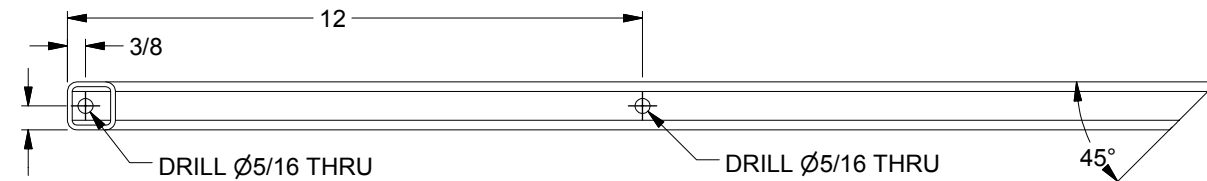
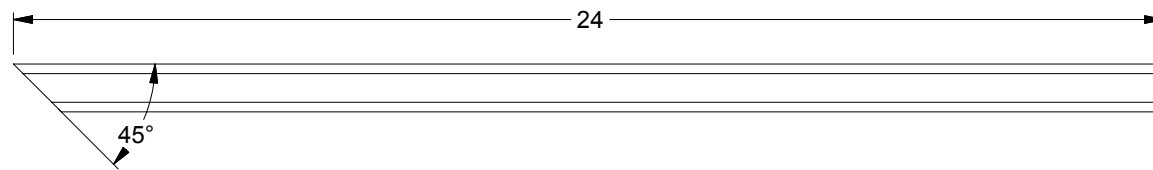

ITEM: 2 PART NAME: LONG LEG LH QTY: 1
 DESCRIPTION: 1 X 1 X .100 SQ TUBE

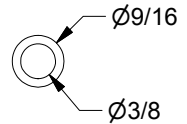
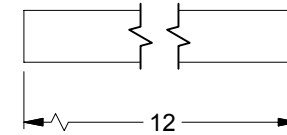

ITEM: 3 PART NAME: LONG WRAP BAR QTY: 1
 DESCRIPTION: 1/4 SCHED 40 PIPE

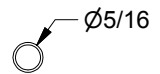
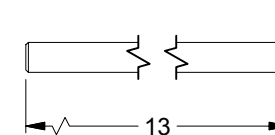

ITEM: 5 PART NAME: LONG THREAD ROD QTY: 1
 DESCRIPTION: 5/16 ALL THREAD

SHT 3

MATERIAL As Specified		DigiPlan	
UPPER LEVEL ASSEMBLY Long Leg Assembly			
WEB ADDRESS www.digiplan.ca		CONTACT INFO prod.support@digiplan.ca	
		DWG NAME Folding Chair	

2

1



2

1

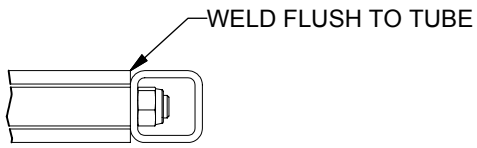

DETAIL B

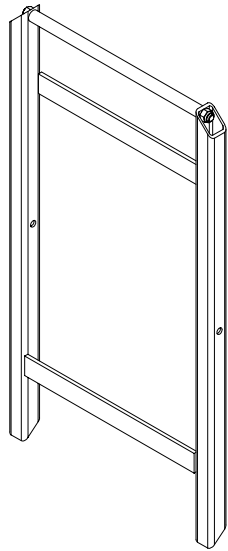

Short Leg Assembly Parts List				
ITEM	QTY	PART NAME	DESCRIPTION	AMOUNT
1	1	Short Leg	1 X 1 X .100 Sq Tube	21.9 in
3	1	Short Leg LH	1 X 1 X .100 Sq Tube	21.9 in
2	1	Short Wrap Bar	1/4 Sched 40 Pipe	10 in
4	2	Short Spread Bar	3/16 X 1 Flat Bar	10 in
5	1	Short Thread Rod	5/16 All Thread	11 in
7	1	5_16-18 NC Hex Nut	5/16 NC Hex Nut	1
6	1	Nylock Nut	5/16 Std NC Nylock Nut	1



B

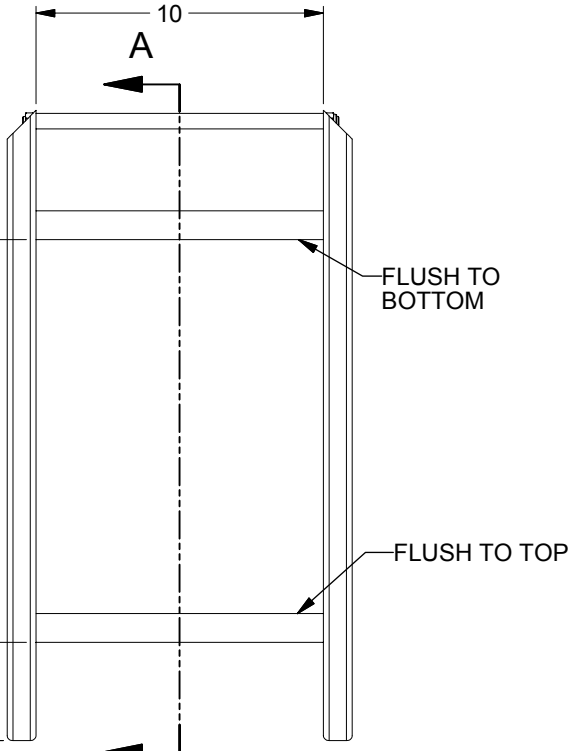

SECTION A-A

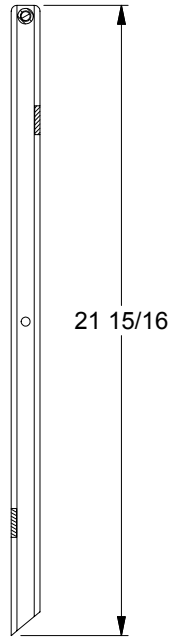

21 15/16

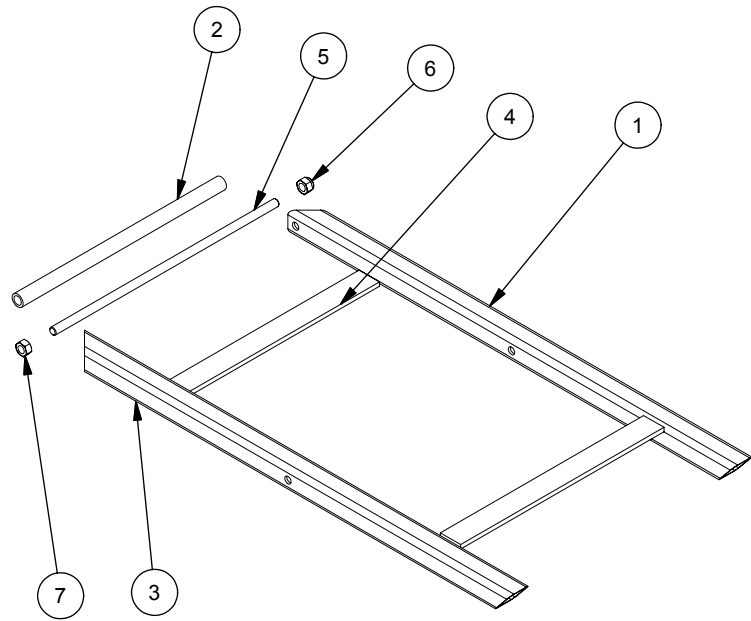

B

B

A

A

SHT 4

MATERIAL		DigiPlan		
Weldment				
UPPER LEVEL ASSEMBLY		DRAWN	QBZ	TITLE
Folding Chair		REV	B	Short Leg Assembly
WEB ADDRESS	CONTACT INFO	DWG NAME		
www.digiplan.ca	prod.support@digiplan.ca	Folding Chair		

2

1

2

1

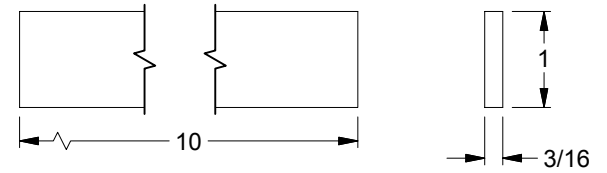
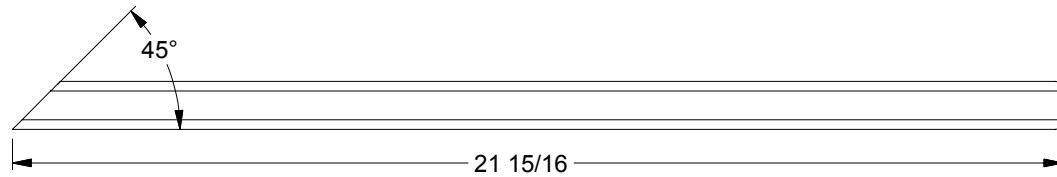

ITEM: 4 PART NAME: SHORT SPREAD BAR QTY: 2
 DESCRIPTION: 3/16 X 1 FLAT BAR

B

B

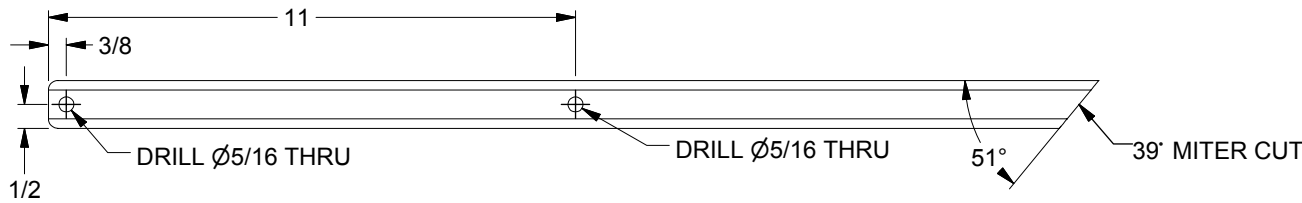

ITEM: 1 PART NAME: SHORT LEG QTY: 1
 DESCRIPTION: 1 X 1 X .100 SQ TUBE

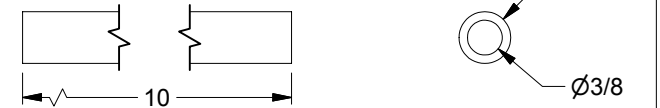

1/2

ITEM: 3 PART NAME: SHORT WRAP BAR QTY: 1
 DESCRIPTION: 1/4 SCHED 40 PIPE

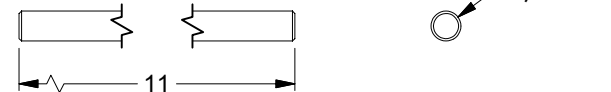
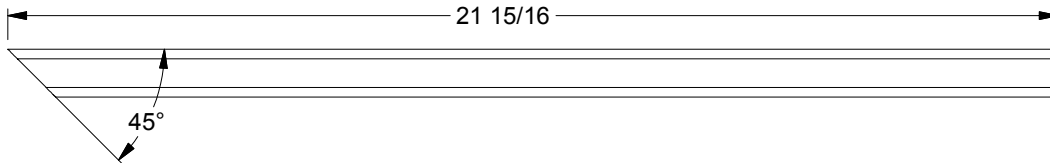

A

A

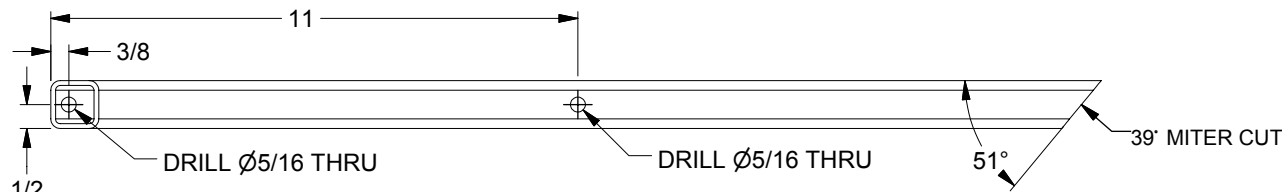

ITEM: 2 PART NAME: SHORT LEG LH QTY: 1
 DESCRIPTION: 1 X 1 X .100 SQ TUBE

ITEM: 5 PART NAME: SHORT THREAD ROD QTY: 1
 DESCRIPTION: 5/16 ALL THREAD

1/2

SHT 5

MATERIAL As Specified		DigiPlan	
UPPER LEVEL ASSEMBLY Short Leg Assembly			
WEB ADDRESS www.digiplan.ca		CONTACT INFO prod.support@digiplan.ca	
		DWG NAME Folding Chair	

2

1

2

1

STITCHING

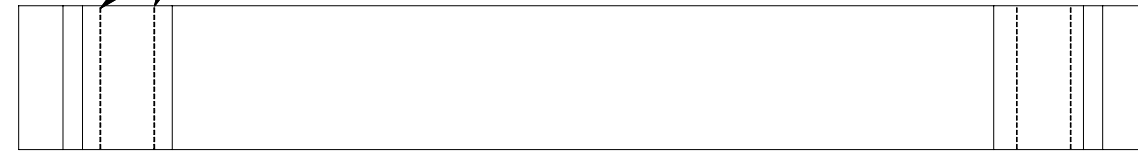

1 1/4

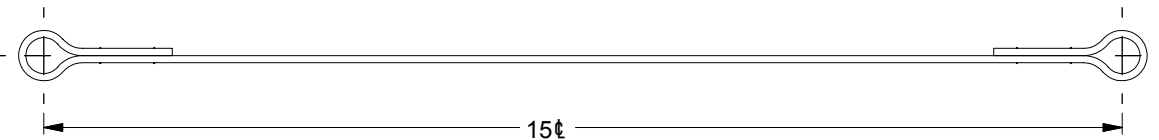

15

ITEM:	PART NAME:	QTY:
1	CHAIR WEB	4
DESCRIPTION:		
1/8 X 2 NYLON WEB		

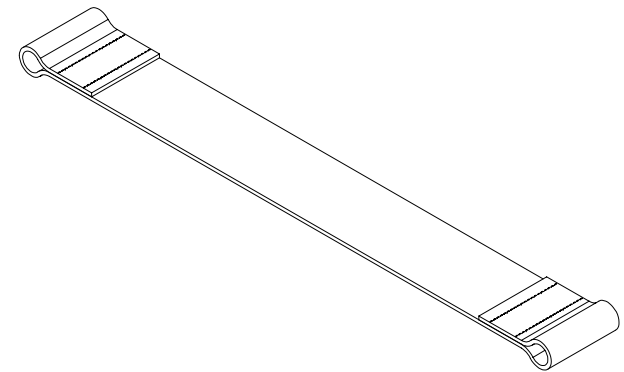

END OVERLAP LINE

4 3/4

4 3/4

2

21

FLAT WEB LAYOUT

SHT 6

MATERIAL		DigiPlan		
1/8 X 2 Nylon Web				
UPPER LEVEL ASSEMBLY		DRAWN	QBZ	TITLE
Folding Chair		REV	B	Seat Strap Web
WEB ADDRESS	CONTACT INFO	DWG NAME		
www.digiplan.ca	prod.support@digiplan.ca	Folding Chair		

2

1